

EVOLUTION™

OXYGEN CONSERVER

OM-900 PRODUCT INFORMATION AND INSTRUCTIONS

- i** **NOTE:** Healthcare Equipment Providers shall provide the end user with instructions for use and instructions for determining gas cylinder contents.
- i** **NOTE:** The gauge face may be different on actual unit.

drive™



TABLE OF CONTENTS

Important Information to Record.....	2	Disassembly Instructions.....	17
Symbol Definitions.....	3	Caring for Your Conservor.....	17
Important Safeguards, Dangers, Warnings and Cautions.....	3	Troubleshooting.....	18
Introduction.....	7	Oxygen Cylinder Duration.....	19
Intended Use.....	8	Information for Home and Healthcare Providers.....	19
Contraindications.....	8	Disinfection Between Patients.....	19
Important Parts.....	9	Disinfection Intervals.....	21
Standard Product.....	11	Maintenance.....	21
Setting up Your Conservor.....	11	Calibration.....	22
Assembly and Use.....	12	Limited Warranty.....	22
Setup.....	13	Disposal Instructions.....	22
Inspection Before Each Use.....	15	Specifications.....	23
Checking for Leaks.....	15	Technical Description.....	24
Operating Instructions.....	16	Electromagnetic Compatibility Information.....	25
		Pneumatic Diagram.....	26

IMPORTANT INFORMATION TO RECORD

Your Name: _____

Date You Received Your Unit: _____

Prescribed Oxygen Flow Setting:

- At Rest: _____
- During Exercise: _____

Home Care Provider's Name: _____

















Home Care Provider's Phone Number: (_____) _____

Physician's Name: _____

Physician's Phone Number: (_____) _____

Notes: _____

SYMBOL DEFINITIONS

	Consult Instructions for Use		Humidity Limit
	Consult accompanying documents		Temperature Limits
	Prescription Only		Type BF Applied Parts
	No Smoking		Contains Natural Rubber Latex
	Use no oil or grease		Serial Number
	Keep away from open flame		Catalog Number
	Use No Oil (on gauge face)		Manufacturer
cf	Continuous flow		Date of Manufacture
	Keep dry, protect the device from moisture		MR Unsafe – Unsafe for Magnetic Resonance Environment



DANGER!

Danger indicates an imminently hazardous situation which, if not avoided, will result in death or serious injury.



WARNING!

Warning indicates a potentially hazardous situation which, if not avoided, will result in death or serious injury.



CAUTION!

Caution indicates a potentially hazardous situation which, if not avoided, may result in property damage or minor injury or both.



NOTE!

Gives useful tips, recommendations and information for efficient, trouble-free use.



NOTE: These symbols may be used in the user manual and also on the device, packaging and other material.

IMPORTANT SAFEGUARDS, DANGERS, WARNINGS AND CAUTIONS

Read and understand this manual before operating your oxygen conserving regulator. Important safeguards are indicated throughout this guide. Pay special attention to all safety information.



DANGER: Danger indicates an imminently hazardous situation which, if not avoided, will result in death or serious injury.

- Oxygen will not burn; however, it does vigorously accelerate the burning of any flammable material.



Oxygen makes it easier for a fire to start and spread. Do not leave the nasal cannula on bed coverings or chair cushions. If the oxygen conserver is turned on but not in use, the oxygen will vigorously accelerate the burning of any flammable material. Turn the oxygen conserver off when not in use.



Smoking during oxygen therapy is dangerous and is likely to result in burns or death. Do not allow smoking or open flames within the same room of the oxygen conserver or any oxygen carrying accessories.

- If you intend to smoke, you must always turn the oxygen conserver off, remove the cannula and leave the room where either the cannula or oxygen conserver is located.



There is a risk of fire associated with oxygen equipment and therapy. Do not use near sparks or open flames.

- Avoid creation of any spark caused by any type of friction, near oxygen equipment.



Not suitable for use in the presence of flammable anesthetic mixture with air, oxygen or nitrous oxide.



Never use oil, grease or petroleum-based products on or near the system to avoid the risk of fire and burns. Wash and dry hands before operating oxygen equipment. Use only water-based lotions or salves.



Do not lubricate replaceable fittings, connections, tubing or other accessories of the oxygen conserver to avoid the risk of fire and burns.

- Never use aerosol sprays near the equipment.



WARNING: Warning indicates a potentially hazardous situation which, if not avoided, will result in death or serious injury.

- Under certain circumstances, oxygen therapy can be hazardous. Seek medical advice before using an OM-900 electronic oxygen conserver.

R_X ONLY The use of oxygen requires a prescription from a physician or other appropriately licensed healthcare practitioner.

- The oxygen delivery setting has been determined for each patient individually with the configuration of the equipment to be used, including accessories.
- If you feel discomfort or are experiencing a medical emergency, seek medical assistance immediately to avoid harm.
- Geriatric or any other patient unable to communicate discomfort may require additional monitoring to avoid harm.
- Be sure to turn off the oxygen supply by setting the flow control knob to "PULSE" when not in use.
- Oxygen flow is only present when the flow indicator is clicked into place. No oxygen will flow if the knob is set between liter flow settings.
- Use of this device at an altitude above 9,800 ft. or an outside temperature of 104° F is expected to adversely affect accurate delivery of oxygen therapy.
- Wind or strong drafts can adversely affect accurate delivery of oxygen therapy.
- This device is not intended to be used during sleep or by patients who breathe more than 40 breaths per minute or consistently fail to trigger equipment.
- The settings of this device may not correspond with continuous flow oxygen.



WARNING (Cont.)

- The conserver must:
 - Be used only after one or more settings have been individually determined or prescribed for you at your specific activity levels.
 - Be used with a specific combination of parts and accessories (i.e. cannulas, tubing) that meet the specifications of the conserver manufacturer, and that were used while your settings were determined.
- Your prescribed settings should be periodically reassessed by a physician or other appropriately licensed healthcare practitioner for effectiveness of therapy.
- The settings of other models or brands of oxygen therapy equipment do not correspond with the settings of the OM-900 Electronic Oxygen Conservers.
- Use only parts and accessories recommended by the manufacturer to ensure proper function and to avoid the risk of fire and burns.
- It is unsafe to modify the equipment, and use or interconnect accessories, detachable parts and materials not described in the instructions for use.
- Cannula tubing can pose a strangulation risk and tripping hazard. Locate tubing away from areas of high foot traffic and keep children and pets away from cannula tubing.
- Always maintain a backup supply of oxygen (i.e. compressed cylinders and regulator).
- Not intended for use with any humidification devices.
- Not for use with an endotracheal tube or tracheostomy.
- Close supervision is necessary when the nasal cannula is used by impaired persons or near children.
- The proper placement of the nasal cannula in the nose is critical to the consistent operation of this equipment.
- Do not use cannula tubing that is longer than 7 ft. (2.13 m).



WARNING (Cont.)

- Before using this unit, make certain that your hands are free of oil, grease or other contaminants, and that the cylinder is secure in an upright position.
- Lint and dust can contaminate the oxygen path and create a fire hazard. Keep all oxygen connections clean and free from lint and dust.
- Make sure the fill valve, if equipped, is clean and free of dirt, debris, oil or other contaminants.
- To reduce the risk of rapid oxygen recompression and fire, open the oxygen source valve slowly and completely so the pressure gauge moves slowly as it indicates the oxygen source pressure.
- Do not wet the area of the oxygen inlet connection, the disinfectant residue may create a risk of fire.
- Do not submerge the conserver in the disinfectant, wipe disinfect only.
- Do not attempt to open or remove enclosure. There are no user-serviceable internal components.
- MR Unsafe. Do not bring the device or accessories into a Magnetic Resonance (MR) environment as it may cause unacceptable risk to the patient or damage to the conserving device or MR medical devices. The device and accessories have not been evaluated for safety in an MR environment.
- Choking Hazard - The 870 post seal washer may pose a choking hazard. Small parts not for children under 3 years or any individuals who have a tendency to place inedible objects in their mouths.



WARNING (Cont.)

- Do not use the device or accessories in an environment with electromagnetic equipment such as CT scanners, Diathermy, RFID and electromagnetic security systems (metal detectors) as it may cause unacceptable risk to the patient or damage to the conserving device. Some electromagnetic sources may not be apparent, if you notice any unexplained changes in the performance of this device, if it is making unusual or harsh sounds, discontinue use. Contact your home care provider. This device is suitable for use in home and healthcare environments except for near active HF SURGICAL EQUIPMENT and the RF shielded room of an ME SYSTEM for magnetic resonance imaging, where the intensity of Electromagnetic DISTURBANCES are high.
- Use of this equipment adjacent to or stacked with other equipment should be avoided because it could result in improper operation. If such use is necessary, this equipment and the other equipment should be observed to verify that they are operating normally.
- Portable RF communications equipment (including peripherals such as antenna cables and external antennas) should be used no closer than 30 cm (12 inches) to any part of the conserving device. Otherwise, degradation of the performance of this equipment could result.



CAUTION: Caution indicates a potentially hazardous situation which, if not avoided, may result in property damage or minor injury or both.

- Prevent water or any other liquid substances from entering the unit.
- Prevent dust, lint or any small particles from entering the unit, as these may degrade performance or cause oxygen leaks.
- Do not expose the unit to extreme temperatures or heat sources such as fireplaces and radiant heaters.
- Do not use humidifier bottles.
- Do not use if leaking or damaged.
- Refer repairs to authorized service personnel.
- Do not use the flow outlet for driving any medical equipment.
- This product contains natural rubber latex (oxygen pressure gauge rubber guard) which may cause allergic reactions.
- Oxygen supplied by this equipment is supplemental only and is not intended for life support applications. The OM-900 electronic oxygen conserver should not be used to supply anything other than medical oxygen.
- Remember that in continuous flow mode, the oxygen will be consumed at a much faster rate. Switch to another oxygen source before depleting the oxygen cylinder. The continuous flow function on the OM-900 electronic oxygen conserver is factory preset at 2 LPM.
- Checking for leaks should be performed before each use.
- To help prevent possible damage to the unit and to maintain its cleanliness, keep the OM-900 electronic oxygen conserver in a carrying bag. Several bags are available for use with different cylinder sizes and configurations: contact your Home Care provider for more information on carry bags.
- Combinations with medical devices other than recommended can alter the performance of the equipment (example: combinations with reservoir cannula, extended length tubing).

SAVE THESE INSTRUCTIONS

INTRODUCTION

This manual provides information necessary to operate the EVOLUTION™ OM-900 electronic oxygen conserver. This conserver can be used with CGA 870 post-valve cylinder [see Fig. A] at home or away from home to provide your specific oxygen requirements. It requires two (2) 1.5 volt AA alkaline batteries for operation.

PURPOSE:

The EVOLUTION™ OM-900 electronic oxygen conserver includes a combination of a low-pressure regulator and an oxygen conserver. It is designed for use with a cylinder as an ambulatory oxygen system and is capable of delivering a specific amount of supplemental oxygen at the optimal point in the breathing cycle. The EVOLUTION™ increases the efficiency in the delivery of oxygen, maximizing the beneficial effects and eliminating unnecessary oxygen waste.

FUNCTION:

When we breathe, approximately one-third of the time is spent inhaling and two-thirds exhaling. As a result, oxygen delivered by continuous flow is wasted during exhalation. By eliminating oxygen flow during exhalation, a two-thirds saving is possible. Additionally, the oxygen available during the very first part of inhalation contributes most to meeting oxygen needs. The OM-900 electronic oxygen conserver takes advantage of these facts to provide maximum efficiency in the delivery of oxygen. This device is designed to be an integral component of a lightweight, long-lasting supplemental ambulatory oxygen system.

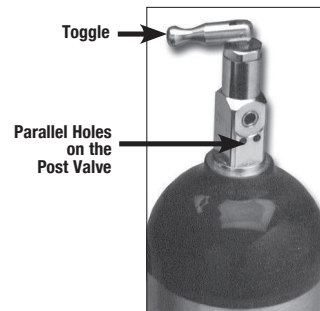

FIGURE A
Post-Valve Cylinder

USER QUALIFICATION:

Prior to beginning therapy, patients must be given instruction by qualified personnel in how to operate this unit.

Functions that are frequently used include:

- Installing the device by connecting to a portable oxygen cylinder post valve.
- Selecting a prescribed oxygen setting on the selector dial.
- Attaching standard oxygen cannula and tubing to gas port and securing cannula to user.
- Monitoring the pressure gauge for remaining oxygen in cylinder.
- Disconnecting the device from the portable oxygen cylinder.

Intended Use:

The EVOLUTION™ Model OM-900 is intended for prescription use only, to be used as part of a portable oxygen delivery system for patients that require supplemental oxygen up to 7 liters per minute, in their home and for ambulatory use.

The patient is the intended operator.

 **CAUTION:** Oxygen supplied by this equipment is supplemental only and is not intended for life support applications. The OM-900 electronic oxygen conserver should not be used to supply anything other than medical oxygen.

CONTRAINDICATIONS:

- This device is not to be used for life support applications.
- This device is not intended for use by patients who breathe more than 40 breaths per minute.
- This device is not to be used by patients who consistently fail to trigger the device.
- The device is not for use while asleep.

 **NOTE:** The OM-900 electronic oxygen conserver will be referred to as the EVOLUTION™ in the remainder of the guide.

IMPORTANT PARTS

1. Low Battery Indicator Light: The EVOLUTION™ incorporates a visual indicator light that alerts you when a battery change is needed. The following signal will be displayed as your batteries become depleted.

Blinking Red Light- Low battery energy level. Replace batteries.

- 2. Cylinder Attachment Knob:** This is used to attach the unit to any CGA 870 post-valve cylinder.
- 3. Selector Knob:** This enables the user to switch between the continuous flow (CF) mode setting and Pulse mode setting. The continuous flow mode setting is designed for emergency use only. The amount of oxygen delivered when using the EVOLUTION™ in continuous flow mode is preset at 2 LPM (liters per minute).

The CF mode is a mechanical override designed as a safety feature in case of battery power failure. When in the CF mode, the user can still change the LED display lights by pressing the Selector Button, but it has no effect on the oxygen output.



FIGURE B
Top View



CAUTION: Remember that in continuous flow mode, the oxygen will be consumed at a much faster rate. Switch to another oxygen source before depleting the oxygen cylinder. The continuous flow function on the EVOLUTION™ converter is factory preset at 2 LPM.

The Pulse mode setting is the normal operating mode and pulses oxygen at the rate set by the Selector Button.

- 4. Selector Button:** This enables the user to select the oxygen dosage setting when the Selector Knob is in the Pulse mode setting. Press and hold the Selector Button until the appropriate dosage LED display light is illuminated. To check your current setting, press and release the Selector Button.
- 5. Oxygen Pressure Gauge:** This enables the user to monitor the contents of the compressed oxygen cylinder.



CAUTION: In the event that it is necessary to operate the unit in the continuous flow mode, DO NOT obstruct the flow of oxygen from the Oxygen Supply Outlet by placing your finger over the outlet or blocking the flow through the oxygen tubing in any way. Doing so may render the unit inoperable and/or damage the sensor in the unit.

IMPORTANT PARTS (cont.)



WARNING: Fire Hazard

Lint and dust can contaminate the oxygen path and create a fire hazard. Keep all oxygen connections clean and free from lint and dust.

6. **Battery Holder:** This compartment holds two (2) AA-size alkaline batteries.
7. **Oxygen Supply Outlet:** Use this fitting to attach a standard cannula.
8. **Cylinder Alignment Pins:** When assembling the unit, these parallel pins must go into the holes on the post valve.
9. **Seal Washer:** This creates the interface between the valve and the EVOLUTION™. Besides offering a rugged interface, it also surrounds the oxygen path in a ring of stainless steel or brass.



WARNING: Use only a manufacturer-specified seal washer. Other seal washers may not be oxygen compatible and may cause an oxygen leak, creating an increased fire risk.

10. **Oxygen Inlet Connection:** Interfaces between cylinder valve and conserver to allow oxygen to flow into the regulator.

10 OXYGEN INLET CONNECTION

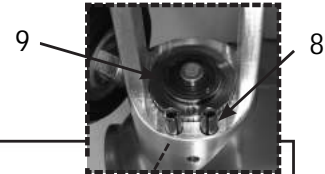

FIGURE C
Side View

6

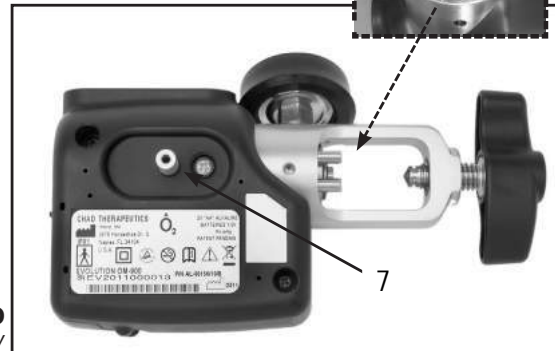

FIGURE D
Bottom View

7

STANDARD PRODUCT

ORDER NUMBER	DESCRIPTION
OM-900	Electronic oxygen conserving device with CGA 870 post connection

REPLACEMENT PARTS

ORDER NUMBER	DESCRIPTION
SEAL-100	870 Post Seal Washer (Gasket)

SETTING UP YOUR CONSERVER



WARNING: Fire Hazard

Before using this unit, make certain that your hands are free of oil, grease and other contaminants, and that the cylinder is secure in an upright position.

NON-PORTABLE USE:

The EVOLUTION™ is designed to extend the life of portable oxygen supplies when away from the primary source. While the conserver may be used with stationary oxygen sources, the unit should be used only while awake. The conserver is not intended for use while asleep.

Conditions in the home healthcare environment that can affect the performance of your device:



WARNING: Fire Hazard

- Lint and dust can contaminate the oxygen path and create a fire hazard. Keep all oxygen connections clean and free from lint and dust.
- Degraded sensors due to rough handling, extreme temperatures or humidity can affect the device's ability to dose oxygen. To avoid this, operate the device within the rated environmental conditions listed in the Specifications section of this guide.

ASSEMBLY AND USE



WARNING: Fire Hazard

- Make certain that your hands are free of oil, grease and other contaminants.
- Inspect the unit to ensure the seal washer (gasket) is in good working condition and attached to the inlet nozzle.
- Secure the cylinder in an upright position.



WARNING: Fire Hazard

- Inspect the valve of the cylinder and the conserver to ensure that they are free of contaminants and damage. If any indication of damage or contamination is detected, **DO NOT** use the equipment and contact your Home Care Provider.



- WARNING:** Use **ONLY** a manufacturer-specified seal washer (gasket). An incorrect seal washer (gasket) may not be oxygen compatible or may cause an oxygen leak, creating an increased fire risk. **DO NOT** use the device if the manufacturer-specified seal washer (gasket) is missing.

SETUP

INSTALLING/CHANGING ALKALINE BATTERIES:

The EVOLUTION™ uses advanced technology that prolongs battery life through efficient power use. With normal use of four (4) hours per day at any setting, your batteries should last a minimum of 2 years.

Two (2) AA alkaline batteries are packaged in the box with your EVOLUTION™. Follow these easy steps to install or change batteries when needed:

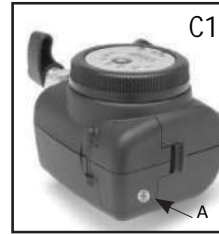

STEP 1: While holding the unit in one hand, remove the Phillips screw [A] that holds the battery door in place, then gently press down on the battery door with your thumb and open the hinge door away from the EVOLUTION™ label [Figs. C1 and C2].

STEP 2: Drop the batteries into the slot, making sure they are inserted in the proper direction as indicated by the (+) and (-) symbols [Fig. C3].

STEP 3: Rotate the door cover back in place until a “click” is heard. Reinstall the Phillips screw [A] that was removed in Step 1, do not overtighten.



NOTE: The EVOLUTION™ is packaged with batteries inside. A special seal is used at the positive terminal to prevent battery oxidation. If it has not already been removed by your Home Care Provider, be sure to remove the seal before using the unit for the first time.

MONITORING BATTERY ENERGY LEVEL:

The EVOLUTION™ is equipped with a low battery indicator light that alerts you when a battery change is needed. The following signal will be displayed as your batteries become depleted:

Blinking red light: Low Battery energy level. Replace batteries.



Disposal of Batteries: Do not dispose of used batteries in the household waste. Contact a public waste disposal authority for proper disposal instructions.

SETUP (Continued)

ASSEMBLY INSTRUCTIONS:

STEP 1: Loosen the cylinder attachment knob.

STEP 2: Lower the EVOLUTION™ conserver over any CGA-870 post-valve cylinder with the alignment pins toward the holes on the cylinder neck [see Fig. B].

STEP 3: Line up the two pins and the seal washer (gasket) with the corresponding holes on the cylinder post valve.

STEP 4: While holding the unit in place, tighten the cylinder attachment knob by turning clockwise [see Fig. B].

i NOTE: The cylinder attachment knob should be aligned with the indentation on the post valve.

i NOTE: Tighten only by hand. The use of a tool to tighten the knob may damage the unit.



FIGURE E
*Attaching the
EVOLUTION™ to the
conserver.*

STEP 5: Attach a standard cannula (7 ft. [2.13 m] or less in length) to the oxygen supply outlet. See Figure F for an illustration demonstrating the proper positioning of the nasal cannula.

INSPECTION BEFORE EACH USE

STEP 1: Examine the outside of the cylinder and regulator assembly for debris, oils or grease and noticeable signs of damage, dents or dings, corrosion, excessive heat or fire damage, pressure leak or any other sign of damage that might cause a cylinder to be unacceptable or unsafe for use.



WARNING: Fire Hazard

If any of these conditions exist, **DO NOT** use the cylinder and contact your healthcare provider for a replacement cylinder.

STEP 2: Check the flow selector knob to be sure it rotates and stops at each setting.

CHECKING FOR LEAKS:



CAUTION: This should be performed before each use.

STEP 1: Close the valve on the oxygen cylinder by turning the valve clockwise.

STEP 2: Depressurize the conserver by inhaling several times using the nasal cannula. The gauge indicator should drop to zero.

STEP 3: Check that all tube connections are tight. If necessary, tighten them **by hand**.



CAUTION: Do not use a tool.

STEP 4: Ensure that the unit is set to the "PULSE" position.

STEP 5: Slowly open the valve on the oxygen cylinder by turning the valve counter clockwise until the needle in the gauge indicator no longer moves.

STEP 6: Close the oxygen cylinder valve again by turning the valve clockwise.

STEP 7: Observe the needle in the gauge indicator for approximately one minute.

- If the needle remains in its position, there is no leak and the device is ready for use.
- However, if the contents indicator shows a continuous decrease in pressure, there is a leak in the system. In this event, contact your Home Care Provider.

OPERATING INSTRUCTIONS:

STEP 1: Make sure that the EVOLUTION™ selector knob is set to the “PULSE” position before opening the oxygen source valve. Battery saving technology has eliminated the need for an “OFF” position. The unit will go to “Sleep Mode” after three minutes of non-use. The unit will turn on again when an inspiration is detected or the Selector Button is pressed.

 **WARNING: Fire Hazard**
To reduce the risk of rapid oxygen recompression and fire, open the oxygen source valve slowly and completely so the pressure gauge moves slowly as it indicates the source pressure.

STEP 2: If a leak is present (see “Checking for Leaks” section above), close the oxygen cylinder valve, check the seal washer and reinstall. If the leak persists, **DO NOT USE THE EQUIPMENT**. Contact your Home Care Provider for repair or replacement.

STEP 3: Check the oxygen pressure gauge to verify that the oxygen cylinder pressure is within the operating range.

STEP 4: To select the setting on the EVOLUTION™ (1-7) that corresponds to the appropriate delivery setting, press and hold the Selector Button until the appropriate dosage LED display light is illuminated.

 **NOTE:** To check your current setting, press and release the Selector Button in the center of the Selector Knob.

STEP 5: Ensure cannula is properly attached to the EVOLUTION™ conserver.

STEP 6: Properly position the cannula with the nasal prongs facing upward and insert the prongs into nose. Wrap the cannula tubing over the ears and position in front of body (see Fig. F).

The conserver will now start to deliver oxygen. The amount of oxygen delivered per pulse is determined by the setting. A sound may be heard each time the unit delivers a pulse of oxygen. Adequate saturation will be achieved because of the precise time in the breathing cycle in which the pulse of oxygen is delivered.



FIGURE F

 **CAUTION:** To help prevent possible damage to the unit and to maintain its cleanliness, keep the EVOLUTION™ in a carrying bag. Several bags are available for use with different cylinder sizes and configurations: contact your Home Care provider for more information about carry bags.

OPERATING INSTRUCTIONS (Continued):

STEP 7: When finished using the system, close the oxygen cylinder valve and continue breathing through the nasal cannula until no further oxygen is detected and the gauge reads "empty".

STEP 8: Remove the nasal cannula.

STEP 9: When not in use, store in a clean, dry location.

DISASSEMBLY INSTRUCTIONS:

To remove the EVOLUTION™ from the oxygen cylinder:

STEP 1: Close the oxygen cylinder valve by turning the valve clockwise.

STEP 2: Deplete residual pressure in the conserver by continuing to breathe through the nasal cannula or by setting the conserver to continuous flow mode until no further oxygen is detected and the gauge reads "empty".

STEP 3: Remove the nasal cannula from the EVOLUTION™ and turn the selector switch to the "PULSE" position.

STEP 4: While holding the unit in place, slowly loosen the cylinder attachment knob by turning counter-clockwise (see Fig. B on pg. 9).

STEP 5: Pull the unit away from the cylinder post valve until the two alignment pins are out of the holes on the cylinder post valve.

STEP 6: Lift the unit off of the cylinder post valve. Use caution while lifting the unit off of the post valve, as the alignment pins can damage sealing surfaces on the post, increasing the chance of leakage.

STEP 7: Store in a clean, dry location.

CARING FOR YOUR CONSERVER

 The EVOLUTION™ should be kept clean and free from moisture and dust, as well as extreme temperature. Clean the EVOLUTION™ once a week by wiping the outer surface and oxygen outlet port with a clean, dry cloth. Do not use oil or products containing oil.

 Do not expose the unit to water, such as when bathing or swimming. It is advisable to keep the system in its carrying bag to afford a degree of protection. Clean the outside of the unit periodically with a clean, lint-free cloth. To remove heavy soil, wipe unit using a lint-free cloth, dampened with clean water, then dry unit with clean, dry, lint-free cloth. Pay special attention to the oxygen outlet to make sure it remains free of dust, etc.



WARNING: There are no user serviceable parts. Do not attempt to service the device while it is in use.

TROUBLESHOOTING

PROBLEM	PROBABLE CAUSE	SOLUTION
Unit does not pulse.	Software needs to be reset.	Open the battery door and remove the batteries. Wait 10 seconds. Replace the batteries and close the battery door.
	Dead batteries.	Replace batteries.
	Batteries installed incorrectly (reversed).	Make sure battery polarity is correct.
	Dirty battery holder contacts.	Remove the batteries. Use rubbing alcohol and a cotton swab to clean contacts.
	Cylinder valve is closed.	Turn cylinder valve clockwise to open.
	Cylinder is empty.	Check the oxygen gauge. Replace the cylinder, if empty.
	Oxygen cannula is blocked or kinked.	Remove kinks. Clean or replace, if necessary.
Short battery life.	Non-alkaline batteries are used.	Make sure the batteries inside the unit are alkaline.
	Batteries are faulty.	Replace batteries. (See "Installing Alkaline Batteries" section).

Non-functioning units are subject to warranty provisions and the manufacturer repair/return policy. If necessary, call your Home Care Provider.

i NOTE: Do not attempt to open the unit. If the unit is opened or tampered with, the warranty is void.

OXYGEN CYLINDER DURATION

Because the total delivery of oxygen via the EVOLUTION™ is related to breathing rates, it is user adaptive. The total oxygen delivered per minute will automatically adjust with user need, as expressed by increased or decreased breathing rates. For example, at all settings, twice as much oxygen per minute will be delivered if one breathes twenty (20) times per minute as compared with ten (10) times per minute. Please refer to the table below as a guide.

EVOLUTION OM-900	SETTING	1	2	3	4	5	6	7	CF 2 LPM	
CYLINDER TYPE	CYLINDER VOLUME	Estimated Cylinder Duration in Hours (based on 20 breaths per minute)								
M6(B)	164 liters	10.9	6.1	4.2	3.0	2.5	2.0	1.7	1.4	
ML6	171 liters	11.4	6.3	4.4	3.2	2.6	2.1	1.8	1.4	
M9(C)	246 liters	16.4	9.1	6.3	4.6	3.7	3.0	2.6	2.1	
D	425 liters	28.3	15.7	10.9	7.9	6.4	5.2	4.4	3.5	
E	680 liters	45.3	25.2	17.4	12.6	10.3	8.4	7.1	5.7	

INFORMATION FOR HOME AND HEALTHCARE PROVIDERS

DISINFECTION BETWEEN PATIENTS:

Drive Medical recommends that at least the following procedures be completed by an appropriately trained individual (i.e., biomedical technician, equipment technician, respiratory therapist, nurse) between uses by different patients.

STEP 1: Dispose of nasal cannula.

STEP 2: Cleaning Instructions:

- Clean the exterior of the device with:
 - a clean, lint-free cloth to remove surface dirt and soil.
 - a clean, lint-free cloth dampened with water to remove heavy soil.
 - a soft-bristled brush dampened with water to remove stubborn soil.
- Dry the device with a clean, lint-free cloth.

 **NOTE:** Ensure that the oxygen inlet remains free of dust, etc.

STEP 3: Disinfection Instructions:

- Saturate a clean, lint-free cloth with a suitable disinfecting agent (e.g., 1:5 chlorine bleach [5.25%] and water solution) and wipe the exterior of the device.

 **NOTE:** Ensure that the device remains visibly wet for ten minutes, with the solution reaching all crevices and hard-to-reach areas.

 **WARNING:** Do not wet the area of the oxygen inlet connection, the disinfectant residue may create a risk of fire. Do not submerge the conserver in the disinfectant, wipe disinfect only.

STEP 4: Allow all parts to dry completely before checking for proper operation.

STEP 5: Check the oxygen conserver for proper operation:

- Press and hold the Selector Button and ensure that each pulse setting can be selected and that each Dosage LED illuminates.
- Ensure the flow selector knob rotates and clicks into each setting.
- Attach the device.
- Ensure the pressure gauge is working.
- Ensure the flow is working.
- Set the device to each setting, and verify that oxygen pulses.

If the device is operating properly, it is ready to be used by another patient. If the device is not operating properly, the provider should return the device to Drive Medical for service.

 **NOTE:** There is no portion of the gas pathways through the conserver that could be contaminated with body fluids or expired gas under normal or single fault conditions.

DISINFECTION INTERVALS:



WARNING: Do not attempt to open or remove enclosure. There are no user-serviceable internal components.



NOTE: The disinfection process can only be performed by an appropriately trained individual.

PART/ACCESSORY	RECOMMENDED DISINFECTION INTERVAL	COMPATIBLE DISINFECTION METHOD
Outside surface of the conserver and controls	Between patients	1:5 chlorine bleach (5.25%) and water solution
Oxygen Tubing, nasal cannula	Do not clean, replace between patients	N/A

MAINTENANCE

The oxygen conserver does not need maintenance through the expected service life of the product. The device has an expected service life of 5 years, which is based on 1460 hours/year of use under normal operating and storage conditions.

PREVENTIVE MAINTENANCE:

Before attaching the conserver to an oxygen cylinder:

- Examine the seal washer and replace if it is damaged or contaminated with dirt, debris, oil or other contaminants.
- Inspect the threads on the cylinder attachment knob, make sure that the knob turns freely through its full range of adjustment.

To replace the SEAL 100 Seal Washer:

1. Remove the old seal washer by lifting the edge of the brass washer and removing the seal washer from the oxygen inlet connection, discard old seal washer.
2. Wash and dry hands before handling the new seal washer.
3. Place the new seal washer over the oxygen inlet connection and press it against the body of the device to seat the seal washer in place.

CALIBRATION

No calibration is necessary through the expected life of the product.

LIMITED WARRANTY

The EVOLUTION™ conserver has been carefully manufactured and inspected and is warranted to be free from defects in workmanship and materials. Under this warranty, Drive Medical's obligation shall be limited to the replacement or repair of any such units or parts that prove, by Drive Medical's inspection, to be defective within two years from the date of purchase. Any abuse, operation other than the intended use of the product, negligence, accident or repair by other than authorized service professionals shall immediately void this warranty. This warranty does not extend to spare parts or accessories.

Drive Medical will not accept damages or charges for labor, parts or expenses incurred in making field repairs, except upon written authorization prior to such action.

The foregoing warranty is exclusive and in lieu of all other express warranties. Implied warranties, if any, including but not limited to the implied warranties of merchantability and fitness for a particular purpose, shall not extend beyond the duration of the express warranty provided herein. In no event shall Drive Medical be liable for loss of use or profit or other collateral, special or consequential damages.

DISPOSAL INSTRUCTIONS

The equipment, including accessories and internal components, does not belong in your regular household waste. Such equipment is manufactured from high-grade materials and can be recycled and reused. The plastic components should be recycled as plastics.

The device should be destroyed or made unusable prior to disposal, example: remove the internal PC board.

Dispose in accordance with local ordinances.

Disposal of Batteries: Do not dispose of used batteries in the household waste. Contact a public waste disposal authority for proper disposal instructions.

SPECIFICATIONS

DELIVERED OXYGEN VOLUME PER BREATH (ml)						
Setting	Breath Rate (BPM)					
	15	20	25	30	35	40
1	11	11	11	11	11	11
2	20	19	20	19	20	19
3	29	28	28	28	28	28
4	37	37	37	37	37	37
5	46	46	46	46	45	40
6	55	55	55	54	47	40
7	64	64	48	44	36	31

Deviation of delivered oxygen per breath = +/- (1 ml/breath + 10% of the set initial value per breath)

Tested per ISO 80601-2-67:2014 Sec 201.12.1.101

Continuous Flow Rate Setting cf = 2 LPM +/- 0.4 LPM

Tolerance on measurements = +/- 15% (including measurement uncertainty)

All volumes and flows are expressed at STPD (standard temperature and pressure, dry)

Continuous Flow Emergency Bypass System Setting:	Factory preset at 2 LPM
Regulator:	Brass high-pressure with aluminum low-pressure materials
Dimensions (LxHxW):	Approximately 16.5 cm (6.5 in) x 10.2 cm (4.0 in) x 8.3 cm (3.3 in) conserver only
Weight:	Approximately 20.0 ounces (567 grams) conserver with batteries
Operating Temperature:	41°F to 104°F (5°C to 40°C)
Operating Relative Humidity:	15% to 93% non-condensing
Operating Altitude:	-1,200 to 9,800 ft.
Operating Atmospheric Pressure:	1,060 to 700 hPa
Operating Inlet Pressure:	500 to 3000 psig (34.5 to 206.8 bar)
Storage/Transportation:	-13°F to 158°F (-25°C to 70°C) RH up to 93% non-condensing
Shock:	IEC 60601-1-11:2010
Vibration:	IEC 60601-1-11:2010
Pneumatic Inspiratory Trigger Sensitivity:	0.03-0.56 cm H ₂ O sensitivity: (0.01-0.22 in H ₂ O) (under test conditions in ISO 80601-2-67:2014 sec. 201.12.1.101)
Breathing Frequency Range:	3 to 40 bpm
Ingress Protection Rating:	Keep Dry
Batteries:	(2) x 1.5 volt Alkaline type AA
Low Battery Indicator-Blinking LED:	Low Battery Energy Level, replace batteries

Technical Description

How the device functions:

The EVOLUTION™ includes a combination of a low-pressure regulator and an oxygen conserver. It is designed for use with a cylinder as an ambulatory oxygen system and is capable of delivering a precise amount of supplemental oxygen at the optimal point in the breathing cycle. The EVOLUTION™ greatly increases the efficiency in the delivery of oxygen, maximizing the beneficial effects and eliminating unnecessary oxygen waste. The EVOLUTION™ is designed to sense the precise moment in the patient's breathing cycle when it has to deliver the oxygen pulse. It accomplishes its intended purpose by providing supplemental oxygen to a patient requiring nasal oxygen therapy in a manner that yields a high level of efficiency in the consumption of the oxygen administered. The EVOLUTION™ conserver's responsive and rapid oxygen delivery time increases the oxygen concentration provided to the patient, thus increasing the ability to better maintain patient saturation levels.

Principles of dosing, timing, triggering and settings:

The EVOLUTION™ delivers a uniform oxygen pulse which ensures that, if you breathe faster, you will still receive the same amount of oxygen with each breath. The device is electrically powered using electronic and mechanical components. A pulse dose of oxygen is triggered by sensing a pressure drop at the beginning of inhalation and is timed to deliver the dose within the first half of the inhalation. A setting of 1 produces the smallest dose, and a setting of 7 produces the largest dose. The cf setting produces continuous flow of 2 liters per minute.



NOTE: The components in the medical gas path and the nasal cannula are considered applied parts.



CAUTION: Combinations with medical devices other than recommended can alter the performance of the equipment (example: combinations with reservoir cannula, extended length tubing).

Electromagnetic Compatibility Information

Test Description	Specification	Notes	Results
CISPR11 & IEC 60601-1-2:2014 (4th Edition)			
Radiated Emissions	EN 55011:2009 + A1:2010 FCC Part 15, Subpart B	Class B 30MHz – 1GHz	Complies
Electrostatic Discharge Immunity	EN 61000-4-2:2008	±15kV (Air) 8kV (Contact)	Complies
Radiated Electromagnetic Field Immunity	EN 61000-4-3:2010	80MHz to 2.7GHz @ 10V/m; 80% AM at 1kHz	Complies
Proximity Fields from RF Wireless	EN 61000-4-3:2010	385Mhz – 5785Mhz	Complies
Magnetic Field Immunity	EN 61000-4-8:2009	30A/m @ 50Hz & 60Hz	Complies

Pneumatic Diagram

Pneumatic Diagram depicts device in conserving selection.

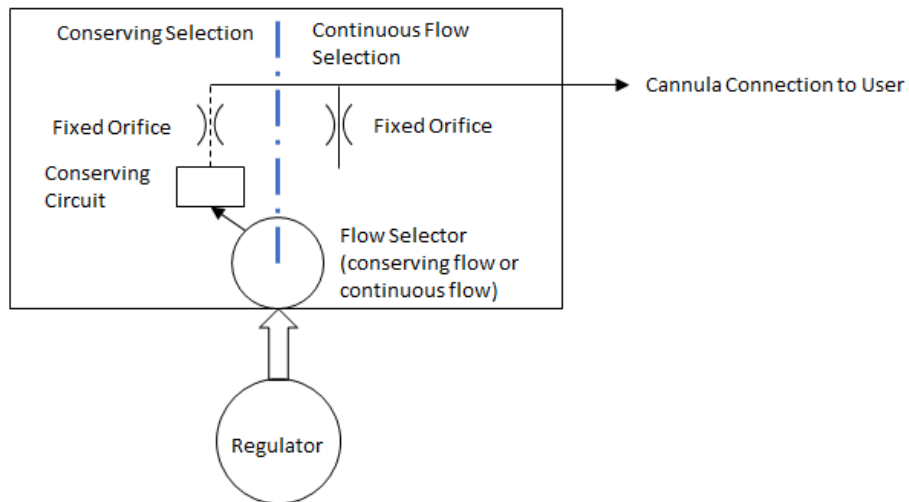

drive[™]



Manufactured by
Inovo, Inc.

401 Leonard Blvd. N
Lehigh Acres, FL 33971
Toll-free: 888-446-6862

PM-00040/19/L
Printed in the U.S.A